

ITEM	DESCRIPTION	SPARES No
1	OPERATING STAT PHIAL MOUNTING BRACKET	535580006
2	OPERATING STAT PHIAL COVER	535580007
3	SAFETY THERMOSTAT	535580008
4	SAFETY STAT PHIAL MOUNT BRACKET	535670018
5	BURNER ASSEMBLY (NO INJECTORS)	535670019
6	BURNER INJECTORS (x 2) - NAT GAS	535670020
7	BURNER INJECTORS (x 2) - PROPANE	535570004
8	GAS CONTROL VALVE C/W FITTINGS - NAT & PROPANE	535580017
9	PILOT ASSEMBLY - NAT & PROPANE	535580013
9.1	3 FLAME PILOT	530760007
9.2	PILOT INJECTOR - NAT GAS	537350013
9.3	PILOT INJECTOR - PROPANE	537350014
9.4	THERMOCOUPLE	535670024
10	PILOT PIPE C/W FITTINGS	535570005
11	SPARK IGNITOR ASSEMBLY	535670026
11.1	SPARK IGNITOR	535010000
11.2	SPARK IGNITOR CABLE	535710115
11.3	SPARK ELECTRODE	537350007
12	CROSS LIGHTER ASSEMBLY - NAT & PROPANE	535670027
12.1	CROSS LIGHTER INJECTOR - NAT GAS (NOT SHOWN)	535710091
12.2	CROSS LIGHTER INJECTOR - PROPANE (NOT SHOWN)	531300070
13	CROSS LIGHTER PIPE C/W FITTINGS	535720080
14	GAS GOVERNOR - NAT GAS (NOT SHOWN)	535820026

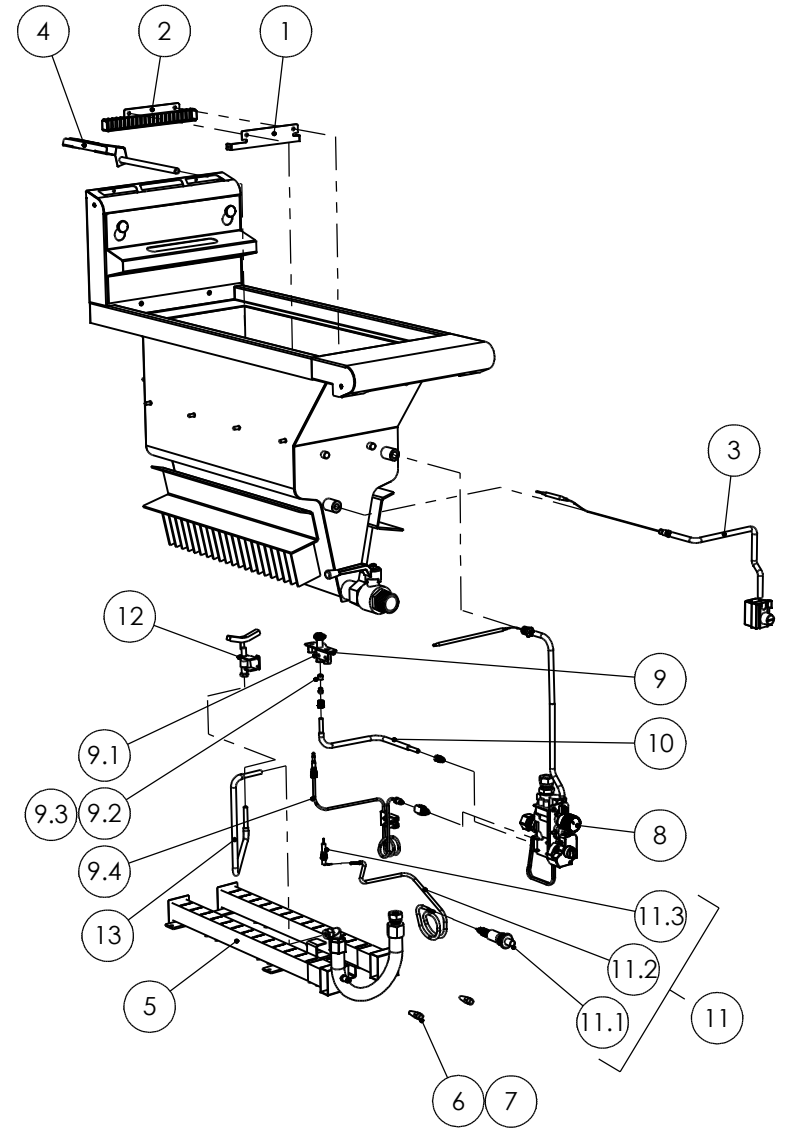

PRODUCTION ISSUE

ISSUE	MOD No	ALTERATION	DRAWN BY	DATE
A	1358/2	PRODUCTION ISSUE	G.SMITH	26/02/13
B	7069	GAS CONTROL VALVE (ITEM 8), SPARES No WAS 535580012	G.SMITH	29/04/14

IF IN DOUBT ASK
DO NOT SCALE
FIRST ANGLE PROJECTION

UNLESS OTHERWISE SPECIFIED:
DIMENSIONS ARE IN MILLIMETERS
TOLERANCES:
LINEAR: ±0.5mm
ANGULAR: ±0.5 DEG

DEBUR AND
BREAK SHARP EDGES

WEIGHT: 171.389.62g



DRAWN: G.SMITH	PRODUCT	G3830 FRYER - MAXITROL	
DATE: 26/02/13	TITLE	SPARES - CONTROLS	
SCALE:	DRAWING NUMBER	AD50025	
MATL:	ISSUE	B	
THICKNESS:	FINISH:		
BIN No:	PART No:		

NO REPRODUCTION OR PUBLICATION OF THIS DRAWING MAY BE MADE AND NO ARTICLE MAY BE MANUFACTURED OR ASSEMBLED IN ACCORDANCE WITH THIS DRAWING WITHOUT PRIOR WRITTEN CONSENT. THIS PROHIBITION IS A TERM OF ANY CONTRACT RELATING TO THIS DRAWING. RIGHTS RESERVED UNDER THE COPYRIGHT ACT 1956 AS AMENDED BY THE DESIGN COPYRIGHT ACT 1968

ITEM	DESCRIPTION	SPARES No
1	DOOR ASSEMBLY	535570000
1.1	DOOR HANDLE	736010020
1.2	DOOR HINGE BUSH (x 2)	536060036
2	DOOR HINGE - TOP	535200006
3	DOOR HINGE - BOTTOM	535200007
4	DRAIN TUBE ASSEMBLY	535710015
5	ADJUSTABLE FOOT	535480067
6	CASTOR - BRAKED (x 2) - NOT SHOWN	536430110
7	CASTOR - FIXED (x 2) - NOT SHOWN	731350014
8	CONTROLS INDICATION LABEL	535580001
9	OUTER SIDE PANEL - RH	535580002
10	OUTER SIDE PANEL - LH	535580003
11	CONTROL PANEL	535570001
12	HOB/PAN ASSEMBLY C/W INSULATION & DRAIN VALVE	535570002
12.1	DRAIN VALVE ASSEMBLY	534510060
13	PAN STRAINER	535670009
14	FISH PLATE	535570003
15	BASKET	531312010
16	DUST COVER	535670010
17	FLUE ASSEMBLY	535670011
17.1	BASKET HANGER	535670012

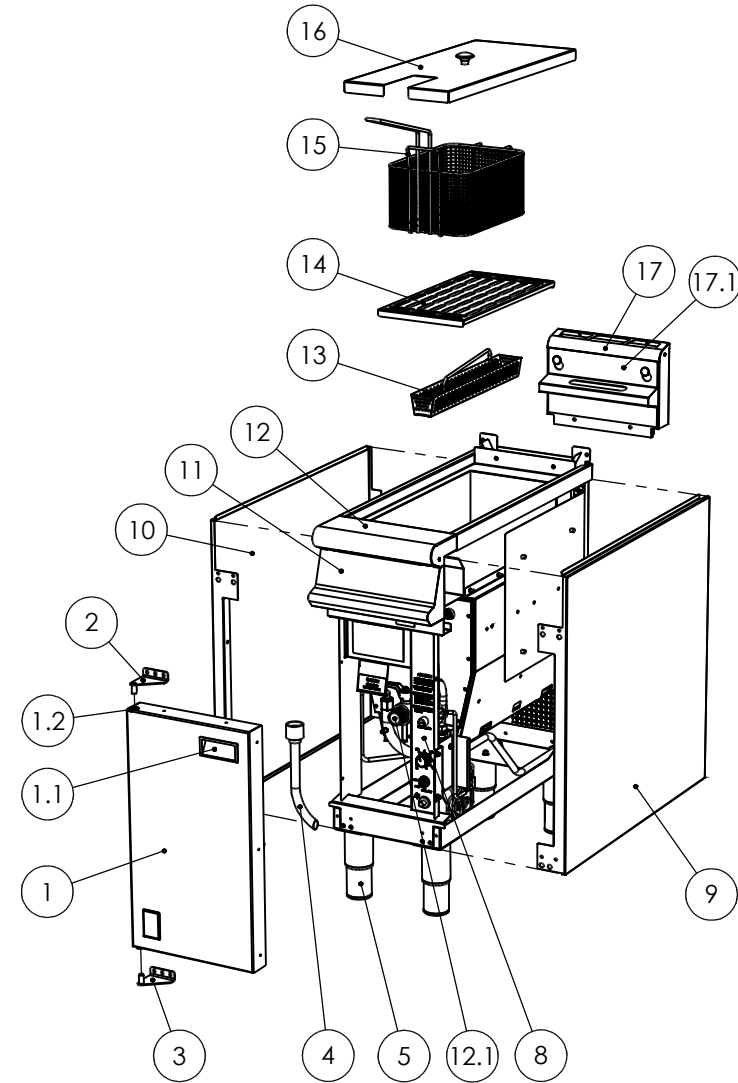

PRODUCTION ISSUE

ISSUE	MOD No	ALTERATION	DRAWN BY	DATE
A	1358/2	PRODUCTION ISSUE	G.SMITH	26/02/13

IF IN DOUBT ASK
DO NOT SCALE
FIRST ANGLE PROJECTION

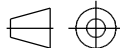

UNLESS OTHERWISE SPECIFIED:
DIMENSIONS ARE IN MILLIMETERS
TOLERANCES:
LINEAR: ±0.5mm
ANGULAR: ±0.5 DEG

DEBUR AND
BREAK SHARP EDGES

WEIGHT: 168222.92g



DRAWN: **G.SMITH**

DATE: **25/02/13**

SCALE:

MATL:

THICKNESS:

BIN No:

PRODUCT

G3830 FRYER - MAXITROL

TITLE

SPARES - MAIN BODY

DRAWING NUMBER

AD50024

ISSUE

A